



# UNITEDSEATS

## MGV35

The MGV35 is a stylish low profile mechanical suspension seat that enhances the aesthetics of new machines as well as providing a safe and comfortable working position for the operator.

This seat is suitable for all types of agricultural, forklift and other small machinery. Available with several options.

International standards met by the MGV35:  
EN 13490 / IT1 / IT2 / EM2 /  
EM4 / EM5 / EM7 / EM8

As a retrofit seat for refurbished vehicles the MGV35 is an ideal replacement unit with slide rails already set at the popular 328 mm mounting centres.

The choice of Heavy Duty water resistant PVC with drainage grooves or quality fabric trim makes it suitable for open or cabbed vehicles.



*We unite your seat*

### STANDARD FEATURES

- Mechanical suspension
- Weight adjustment 50-130 kg
- Suspension travel 80 mm
- Slide rail travel 180 mm
- Slide rails at 328 mm centres
- Heavy duty PVC trim with drainage
- Seat width 460 mm
- Foldable and adjustable backrest
- Seat belt
- Contact switch

### OPTIONS

- UnitedSeats fabric trim
- Mechanical lumbar support
- Adjustable armrests
- Headrest
- Document box

### AFTER SERVICE

- Easy to replace cushion assemblies

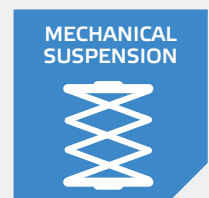



**TECHNICAL  
DRAWING MGV35**

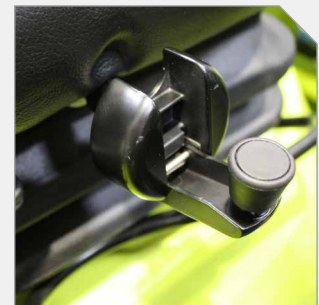
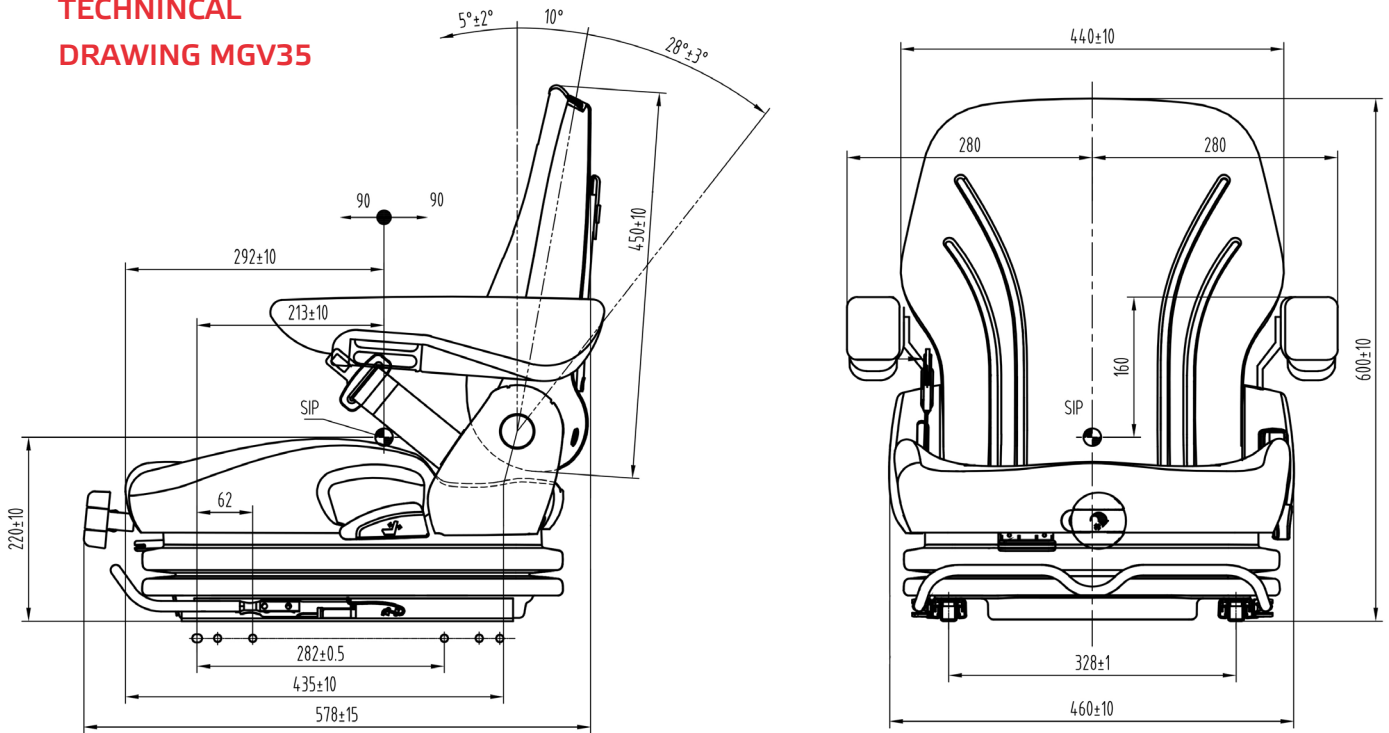

*We unite your seat*



**UNITEDSEATS**  
**T. UK** +44 (0)1604 300 014  
**T. NL** +31 (0)88 0158 700  
**E.** info@unitedseats.com  
**I.** www.unitedseats.com

Your UnitedSeats contact:

Blank box for contact information.

