

**RANCHER**  
**LGV95/H152 ARD**



FABRICANT DE SIÈGES HORS-ROUTE



## RANCHER











Unitedseats présente un nouveau siège AIR le LGV95 / HL152 ARD (Rancher) à dossier bas, pour des machines agricoles, de construction et industrielles. Il comporte des commandes intégrées et un réglage motorisé en fonction du poids et de la taille. Ses coussins offrent un niveau de confort optimaux pour les opérateurs et le siège propose une vaste gamme de réglages pour améliorer l'ergonomie de la cabine. La suspension horizontale réduit le mouvement de choc des amortisseurs avant vers arrière.

Il possède une large variété d'application de trous de montage externes pour faciliter l'installation des fabricants (OEM's) et des utilisateurs du marché des pièces de rechange.





## CARACTÉRISTIQUES STANDARD

 <b>Pneumatic suspension</b> 12V compresseur intégré Course de suspension 120 mm	 <b>Suspension horizontale</b>	 <b>Glissière réglable</b> 210 mm
 <b>Réglage hauteur</b> 80 mm	 <b>Réglage du dossier</b>	 <b>Accoudoirs réglables</b>
 <b>Réglage du poids</b> 50 - 135 kg	 <b>Soutien lombaire mécanique</b>	 <b>Extension du dossier</b>
 <b>Boîte à documents</b>	 <b>Amortisseur réglable</b>	 <b>Plateau tournant 20°/20° pivotant</b>



**Option**  
Garniture en PVC

## OPTIONS

 Ceinture de sécurité



Siège conforme aux normes E5 et E11 - ISO 6683 et IWG 78/764

**POWERED BY**  

Les dimensions sur le dessin technique sont indiquées en millimètres (mm)

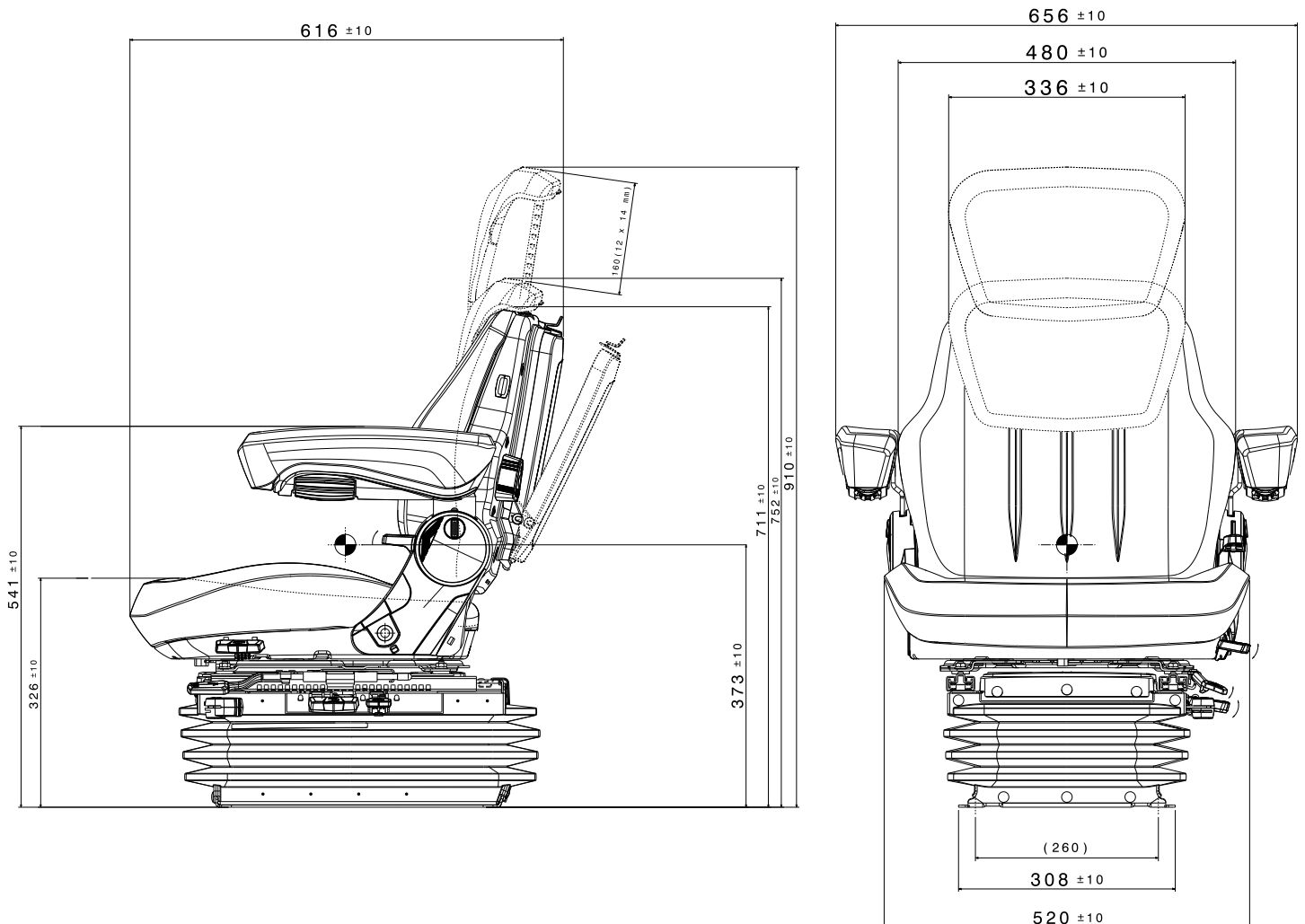



# VOTRE FABRICANT **DE SIÈGES** HORS-ROUTE

Votre représentant Unitedseats:



Chez Unitedseats nous nous engageons à offrir un service de qualité depuis nos premiers contacts commerciaux jusqu'à la livraison de nos sièges. La qualité de nos produits et de notre service font de nous la référence pour répondre à vos besoins.

[WWW.UNITEDSEATS.COM](http://WWW.UNITEDSEATS.COM)

