



# MGV150/C8 PRO MECHANICAL SEAT



QUALITY SEATING MANUFACTURER

# MGV150/C8 PRO MECHANICAL SEAT

The MGV150/C8 Pro is a heavy duty mechanical and seat combination. Featuring a 135 mm suspension stroke and weight adjustment from 50-150 kg, a choice of 3- or 4-point belts, it is suitable for large construction and mining equipment such as excavators, wheel loaders, graders, articulated dump trucks and many others.

Comfort foam cushion with lateral support

Fully adjustable comfortable armrests

Comfortable seat cushion 505 mm width

Seat cushion depth & tilt adjustment

Heavy-duty slide rails

Weight adjustment 50 - 150 kg

320 mm mounting centres

Adjustable comfort headrest

Various safety belts available

Pneumatic lumbar support (2 zones)

Easy to operate fully adjustable backrest

Suspension stroke 135 mm



## OPTIONAL FEATURES

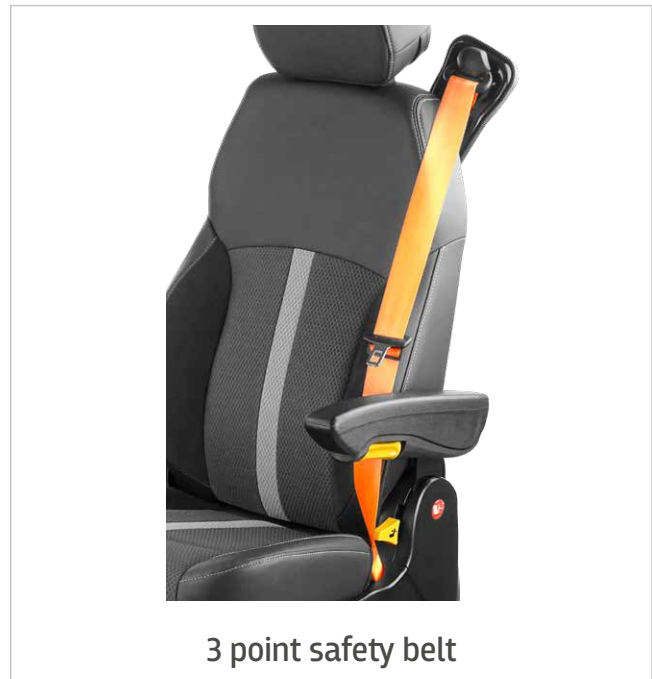

## TECHNICAL DRAWING

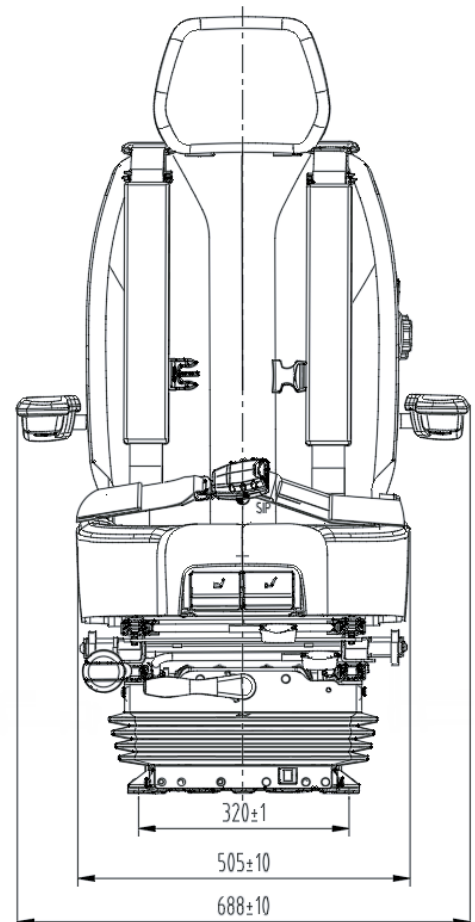
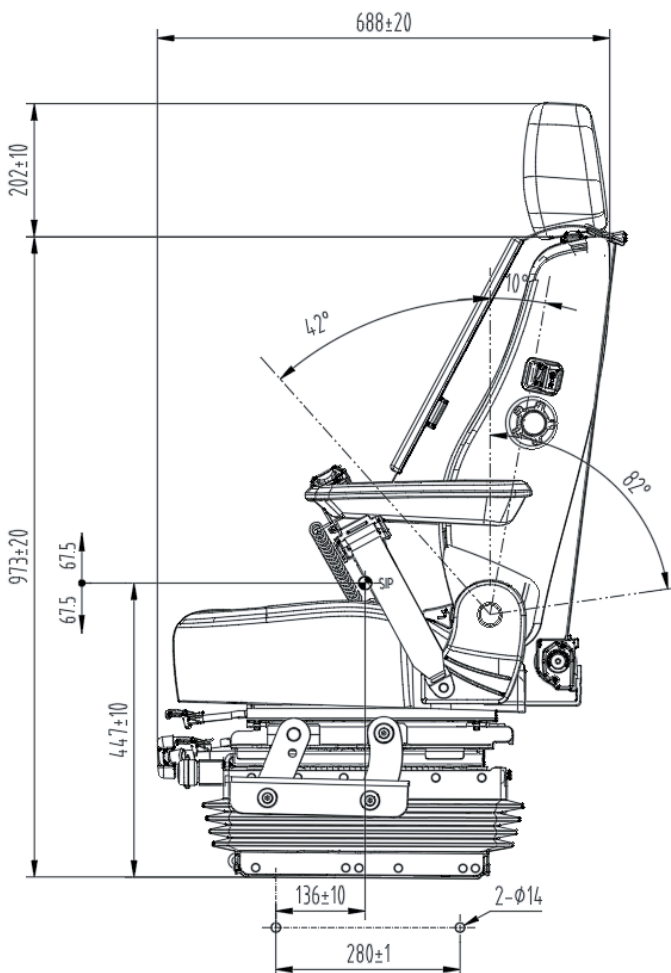



# QUALITY SEATING MANUFACTURER

# Custom made in **Holland**



At UnitedSeats we are dedicated to providing a quality service from the initial quotation to final product delivery. Our commitment to service, knowledge and product availability has made us the preferred source for your seating needs.

[WWW.UNITEDSEATS.COM](http://WWW.UNITEDSEATS.COM)

